



TEST PIECE - Category 2

For year 2, 3 & 4 Training Level

Ducting

Material: Mild Steel
Thickness: 1mm Max
Tolerance: +/- 1.5mm
Dwg issue: 3 20-1-13

Notes

1. The Test Piece must consist of a minimum of THREE (3) or a maximum of SEVEN (7) individual pieces. Wire not included.
2. Any Welding method may be used to join the Test Piece but the welds must be left visible and undressed.
3. The surface of the Test Piece should not be peened or shot blasted. Wire wool rub down is acceptable.
4. The entrant should submit a written account stating the:
The reason for splitting the project the chosen way
Why the joining method was decided and used
Please remove all sharp edges.
5. The Test Piece will be judged on Accuracy and Workmanship.
7. All dimensions are External unless otherwise stated.

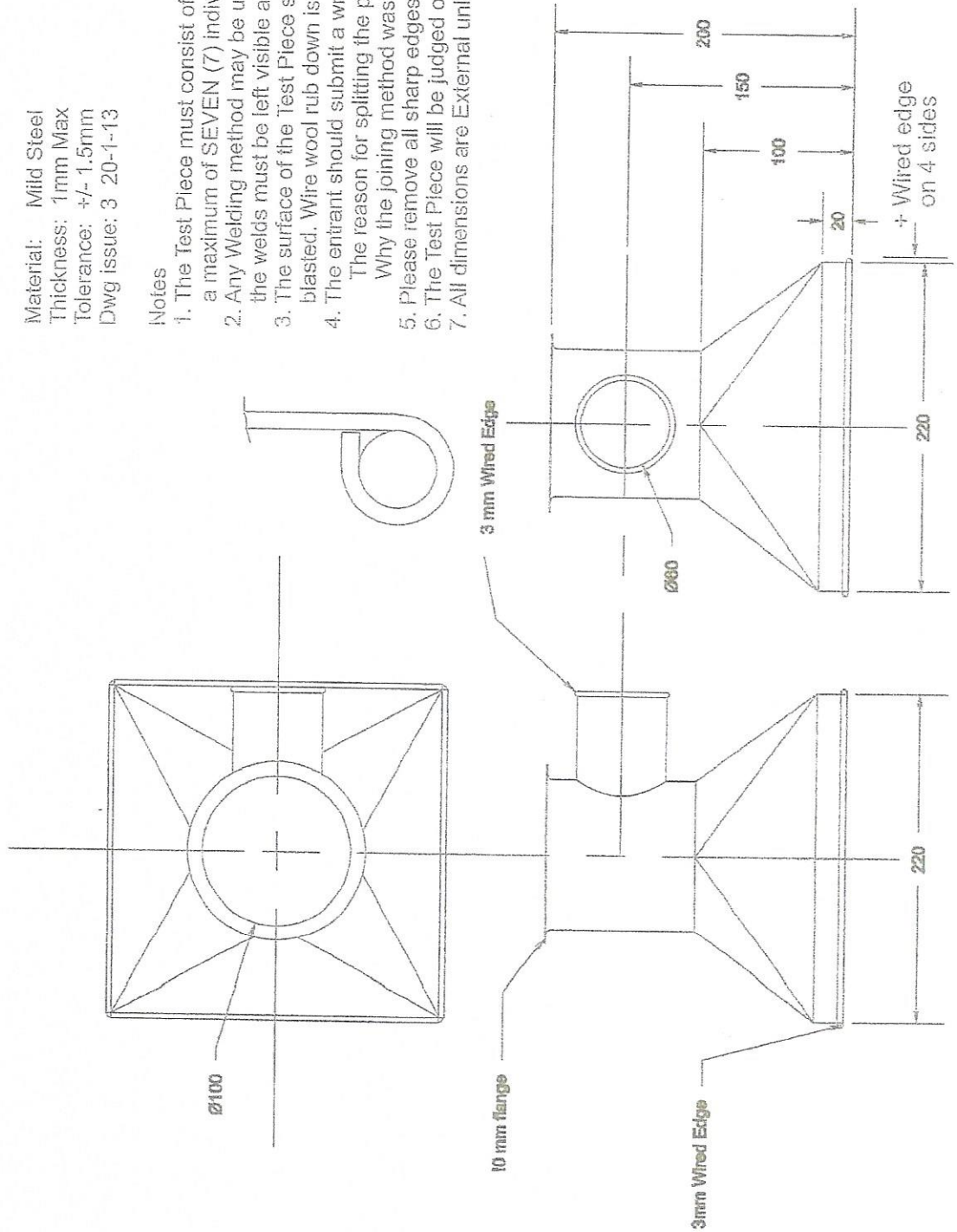



Date _____
Name _____
Competitor Company / Organisation _____

Competitor Number	_____	Judge 1 Initials
_____	_____	_____
Part Description	DUCTING Year 2 & 3 trainees	Judge 2 Initials
Material	Mild Steel CR3 (DC03) 0.9 / 1.2	_____
General Tolerance	+ - 2mm	Judge 3 Initials
_____	_____	_____

All dimensions are External unless otherwise stated.

To Be Checked Dimension or Feature	Max Mark	Judges dimensional and visual verification	Mark Awarded	Judges Comments Trainee's Dimn readings
Ducting				
1 20	5			
2 100	5			
3 150	5			
4 200	5			
5 220 x 220	5			
6 Diameter 100	5			
7 Diameter 60	5			
8 Flange width 10	5			
9 Wired Edge size 3mm and detail tube	5			
10 Wired Edge (4 sides) 3dia wire and detail	5			
11 3 to 7 components	5			
12 Welding / assembly Fit & Finish	10			
13 General surface fininsh	5			
	70	Make Total		
Written Planning Document				
14 Health & safety Awareness	5			
15 Introduction	5			
16 Make process planning	5			
17 Use of Pictures & Diagrams	5			
18 Review	5			
19 Minimum 200 words hand written	5			
		Written Total		
Total	30		Overall Total	

Marking Criteria	Mark	General Comments	Position Test Piece
Selected Main Dimensions	55		
Secondary Dimensions	0		
Spot welding and assembly fit & finish	10		
General Surface Finish	5		
Written Total	30		
Total Marks	100	HEAD JUDGE SIGNATURE	
Dimensions in tolerance Full Marks			
Dimensions out of tolerance No Marks			
Items 12-13 Subjective Judges Decision			
Written Subjective Judges Decision			

PLEASE NOTE; THIS MARKING SHEET IS FOR THE BENEFIT OF THE COMPETITION COMPETITORS.

Part of todays skills requirement is self validation. It is expected that the trainee measures the test piece and puts dimensional readings in end column. A copy of this should be in the written planning document.

*Included in the written planning document must be
approximately 200 words about yourself HAND WRITTEN
A copy from your test piece document is acceptable.